

Fences, Railings, & Traffic Barriers

8

TECHNICAL BULLETIN

This Technical Bulletin is the eighth in a series of informational papers that provide specific application ideas and installation tips for VERSA-LOK® Retaining Wall Systems. Additional information is available in our *Design & Installation Guidelines*.

The information, including technical and engineering data, figures, tables, designs, drawings, details, suggested procedures, and suggested specifications, presented in this publication is for general information only. While every effort has been made to ensure its accuracy, this information should not be used or relied upon for any application without verification of accuracy, suitability, and applicability for the use contemplated, which is the sole responsibility of the user. A final, project-specific design should be prepared by a qualified, licensed, professional engineer based on actual site conditions. VERSA-LOK Retaining Wall Systems disclaims any and all express or implied warranties of merchantability fitness for any general or particular purpose, trademark, or copyright in regard to information or products contained or referred to herein.



Often fences, stair rails, guide rails, or concrete traffic barriers are needed behind a VERSA-LOK wall. With proper design and installation, a variety of structural and aesthetic features can be placed at the top of a VERSA-LOK wall.

This bulletin provides a general discussion regarding the design and installation of fences and railings. However, conditions and loadings vary with each project and these guidelines are not intended as construction drawings for any specific project. The user is responsible for complying with all applicable building codes and obtaining a final, project-specific design prepared by a qualified professional engineer for a wall and any appurtenant structures.

FENCES

When there is sufficient space, the easiest and most cost-effective way to install fences above VERSA-LOK walls is to place them several feet behind walls. With sufficient fence post depth and setback, the soil can provide a stable foundation. Separating fence posts from a wall also keeps wall movement from affecting the fence. While a minimum post depth of 30 inches is suggested, the embedment and distance behind the wall needed to create a stable post foundation varies and depends on the soil conditions.

When a fence is set back behind a wall, installers can dig or drill post holes after the wall is completed or they can install posts during wall construction. One option is to create post holes during wall construction by placing cylindrical tube forms at planned post locations and backfilling soil around them. After completing the wall, the tubes are filled with concrete and the fence posts set in the concrete (Figure 1).

VERSA-LOK®
Retaining Wall Systems
Solid Solutions.™

6348 Hwy. 36, Suite 1
Oakdale, Minnesota 55128
(651) 770-3166
(800) 770-4525
(651) 770-4089 fax
www.versa-lok.com

FIGURE 1 Post Detail — Typical Section
Handrail or Fence Post (Set back from wall)

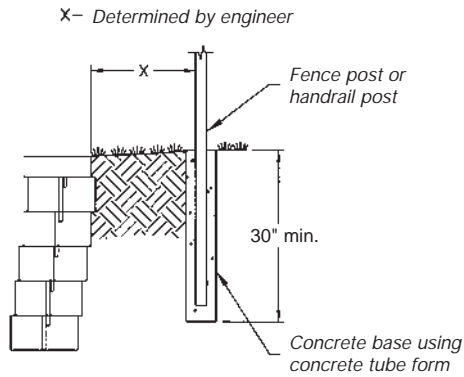

When there is not enough room to set fence posts behind walls, they can be installed within top wall units prior to backfilling behind the wall. Break off the backs of the top few units to create room for the post. Cut or core the cap units to neatly receive posts (Figure 2 and 3). The fence should be flexible enough to accommodate differential movement between the units and the fence.

Placing posts near the front of a wall decreases the fence's foundation support. To improve stability to the post, the concrete foundation should be enlarged, extended behind the wall, and reinforced with steel rebar (Figures 2 and 3). The needed depth, extension length, and rebar placement will vary depending on conditions and loading.

FIGURE 2 Post Detail — Section A-A
Typical Handrail or Fence Post (No Setback)

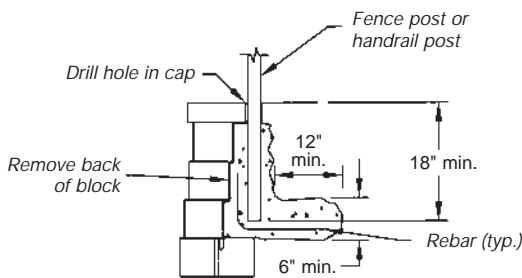
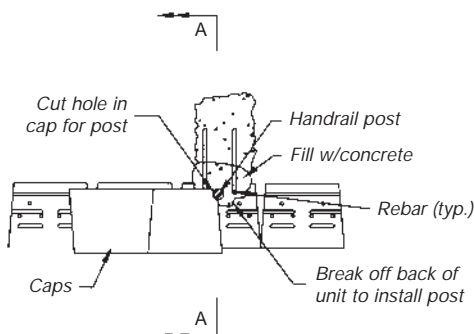

FIGURE 3 Post Detail — Typical Plan
Handrail or Fence Post (No Setback)



GUIDE RAILS

With proper design, guide rails can be used behind VERSA-LOK walls. For proper support, place guide rails several feet behind the wall units (Figure 4). The setback and embedment depth of the guide rail will vary with conditions and loading. For highway loading, AASHTO recommends an embedment depth of 5 feet. Like fence posts, guide rails can be placed in cylindrical concrete tube forms placed during wall backfill.

FIGURE 4 Guide Rail Detail
Typical Section

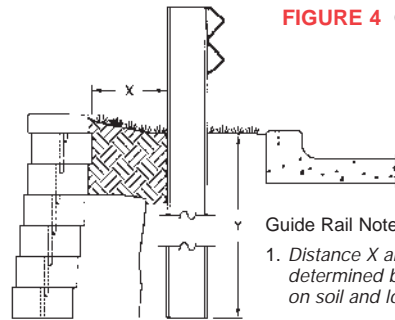

Guide Rail Notes:

1. Distance X and Y to be determined by engineer based on soil and loading conditions.
2. Install H-pile or wood post as per manufacturer's recommendations.

POSTS PENETRATING GEOGRID

For walls requiring soil reinforcement, fence and guide rail posts will often extend below the top layer or two of geogrid. Often the geogrid can be cut to fit around the planned post locations. Usually the top layers of geogrid can accommodate small intrusions while still maintaining overall tensile strength. However, the area cut from the geogrid should be no more than the minimum needed to fit the post. The wall design engineer must evaluate any planned post intrusions into geogrid layers to ensure they do not reduce strengths below needed minimums. Augering or driving through backfilled geogrid after wall construction is generally not suggested because it may excessively disturb or pull geogrid from the soil or the wall units.



When space allows, fences and railings should be placed several feet behind VERSA-LOK walls.

CONCRETE TRAFFIC BARRIERS

When there is no room to set guide rails behind a wall, traffic barriers can be placed directly on top of a wall. These can be cast-in-place concrete or precast barriers (such as Jersey barriers) or a combination of both. Concrete barriers should be designed for stability, independent of the wall. The foundation can be extended behind the wall (moment slab) to act as cantilevered resistance to lateral and overturning loads (Figure 5).

A qualified engineer must design traffic barriers on a project-specific basis. Reinforcing steel, barrier size, and geometry will vary with site conditions and loading. Other design considerations include the need for control joints, expansion joints, and bond breaks to address differential movement between the barrier and the retaining wall. During concrete placement for cast-in-place barriers, temporary bracing of the retaining wall may also be required.

FIGURE 5 Coping Detail — Traffic Barrier Section

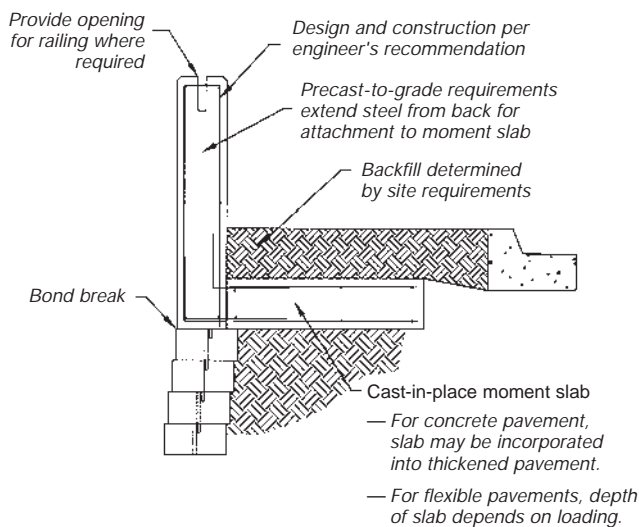

When there is no room to set guide rails behind a wall, traffic barriers can be placed directly on top of a wall.



VERSA-LOK units are adaptable to various stair rail anchoring options.

STAIR RAILS

VERSA-LOK stairs can accommodate a variety of railings with proper design, including railings anchored just above and below steps, into side wall units, or into step risers. Solid VERSA-LOK units allow use of several common techniques for attaching railings to concrete, including fasteners that embed in polymer, grout or mortar, or anchors that cut threads into the concrete. The appropriate fastener varies with loading and site conditions. Refer to the fastener manufacturer's and wall design engineer's recommendations.

When practical, spanning railings from landing to landing and placing posts directly into the soil is usually the easiest way to provide a stable foundation for stair railings. When stairs have numerous risers and spanning is not practical, railings can be attached to the units in the side walls. When there are no side walls, rail posts can be placed through the step units (Figure 6). Step units can be split or cut to extend post hole at least 30 inches deep (more depth may be needed depending on loading). The post hole should be filled with concrete. Caps can be cored to receive the post neatly, if desired.

FIGURE 6 Post Detail — Typical Section
Handrail Post at Stairs

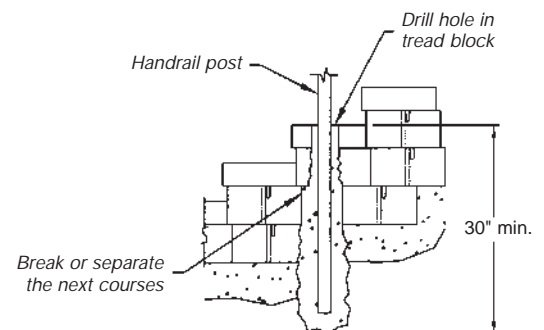



TECHNICAL BULLETIN

For more detailed information regarding design and installation, please contact your local dealer or VERSA-LOK® Retaining Wall Systems.

Made worldwide under license from VERSA-LOK Retaining Wall Systems. U.S. Patent D319,885, U.S. Patent D321,060, U.S. Patent D341,215, U.S. Patent D346,667, U.S. Patent D378,702, U.S. Patent D391,376, U.S. Patent D430,680, U.S. Patent D435,302, U.S. Patent D439,678, U.S. Patent D452,332, U.S. Patent D458,387, U.S. Patent 6,488,448 and other U.S. patents pending;

Canadian Industrial Design Registration No. 63929, No. 71472, No. 73910, No. 73911, No. 73912, No. 77816, No. 79058, No. 82288, and No. 89084.

I.C.B.O. No. 4625

©2004 Kiltie Corporation
Printed in U.S.A. • VLS-508



6348 Hwy. 36, Suite 1
Oakdale, Minnesota 55128
(651) 770-3166
(800) 770-4525
(651) 770-4089 fax
www.versa-lok.com

FREESTANDING WALLS

VERSA-LOK units are often used to create attractive freestanding walls that extend above the top of retaining walls. See Technical Bulletin No. 6 for more information. While these freestanding walls provide excellent aesthetics and visual screening, they should not be relied on to resist lateral loads. If pedestrian or traffic barriers are needed, independent fences or railings designed for the anticipated loads should be installed behind the freestanding wall (Figure 7).

DOUBLE WALLS

When clear views over the tops of walls are desirable, lower, wider barriers sometimes are allowed as alternatives to tall fences. Depending on local building codes, back-to-back VERSA-LOK walls that are spaced far enough apart can act as a pedestrian barrier while providing room for plantings. With proper design and reinforced concrete within the double VERSA-LOK walls, they can also sometimes function as traffic barriers. Check with local codes for application and required width.

FIGURE 7 Freestanding Wall Detail (Straight Walls Only)
Typical Handrail or Fence Post

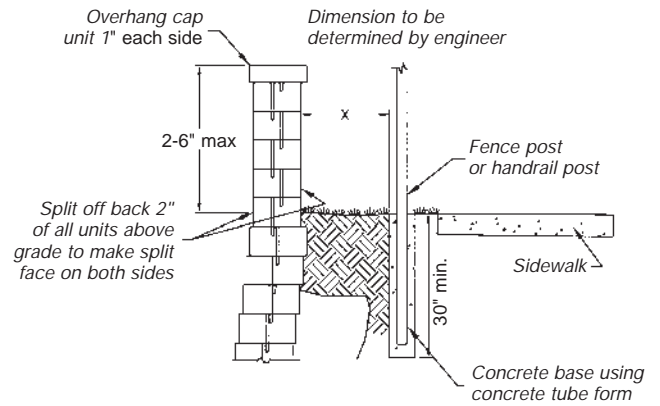

Back-to-back VERSA-LOK walls spaced far enough apart can act as pedestrian barriers while providing room for plantings.